

Note:

1. Question 1 is Compulsory
2. Solve any three from remaining five
3. Figures to right indicate full marks
4. Assume suitable data if necessary

Question	Marks
Q.1	
a) Explain the convergence in FE analysis.	5
b) Explain application of RP in MEMS.	5
c) Explain the significance of Graphic Standards.	5
d) Briefly explain the advantages and disadvantages of NC machines.	5
Q.2	
a) A triangle PQR with vertices P(2,5), Q(6,7) and R(2,7) is to be reflected about the line $y=0.5x+3$. Determine the final transformation matrix and the coordinates of the reflected triangle.	12
b) How do you set work part zero, zero on a CNC machine?	04
c) What are the feedback devices used in NC/CNC machine?	04
Q.3	
a) Write a program in C++ using object oriented concept for 2D transformation which includes function for rotation.	08
b) What do you mean by complex engineering problem? With suitable example, explain the complexities involved and the tools chosen to solve it.	08
c) Enlist CIM hardware and software.	04
Q.4	
a) What do you mean by Synthetic curves? What are the different types of synthetic curves and their continuity conditions?	10
b) Write a manual part program in G - M codes for generating a part as shown in Figure 1 (on next page). Size of raw material is $\phi 85\text{mm}$ by 112mm. Explain each code. Assume suitable data if required. Use canned cycle code for Facing, Turning, and Taper Turning operations.	10

{TURN OVER

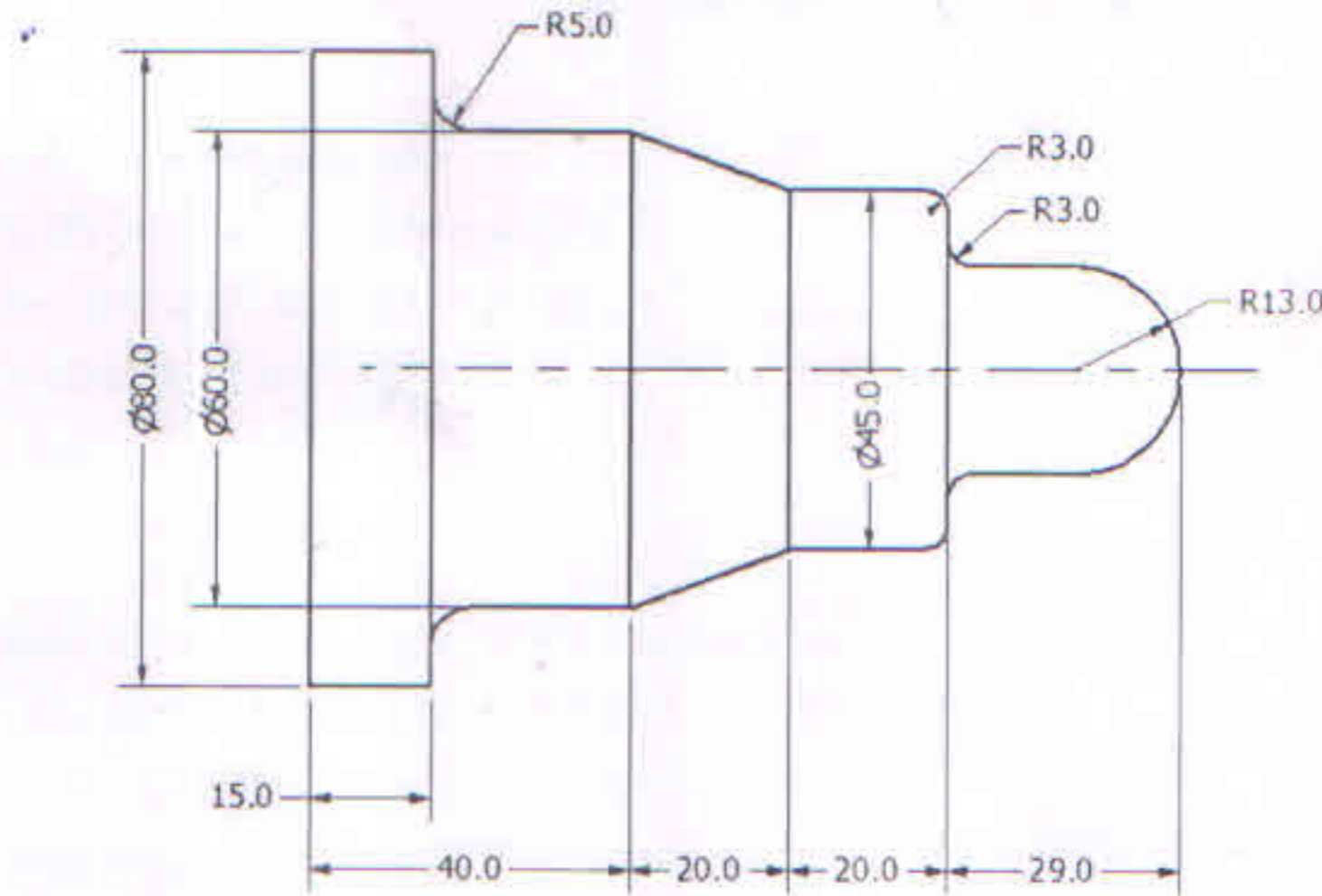

(Fig. 1 The component to be machined. All dimensions are in mm.)

- Q.5 a) Explain the steps used in Rapid Prototyping process. 10
 b) Write a complete APT part program to machine the outline of the geometry shown in fig.2 the top view up to a depth of 5 mm in one cut. The end mill used is 20 mm diameter. Assume suitable speed and feed for machining. Fig.2

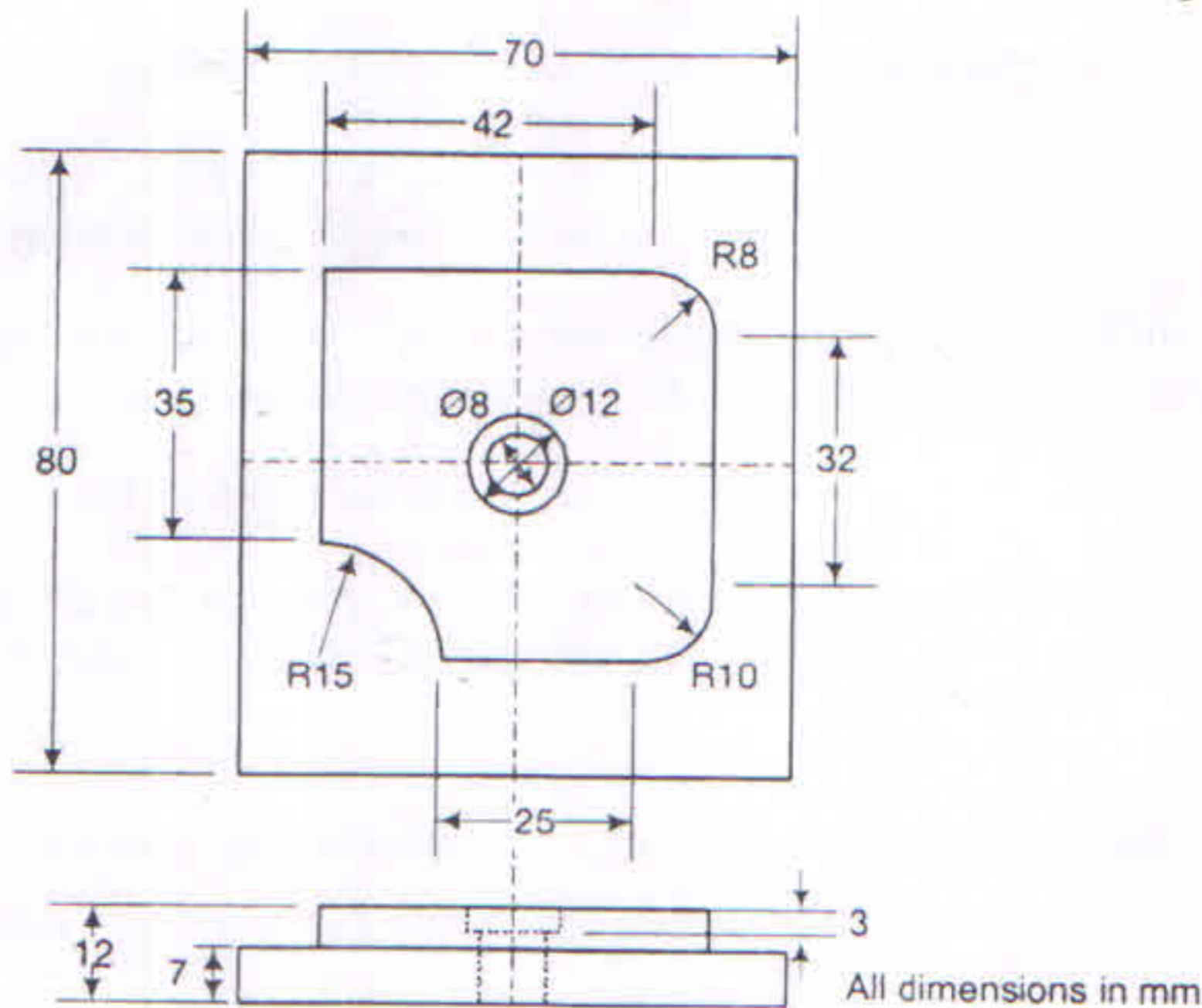

(Fig.2 The component to be machined.)

- Q.6 Write a note on the following (any four) 20
 a) Cohen-Sutherland Clipping Algorithm.
 b) Major steps of FEM.
 c) Fused Deposition Modelling(FDM)
 d) Absolute versus incremental positioning in NC Machine tools.
 e) Affine Transformation and its properties.